

COUGAR 1400

CLAAS



CLAAS U. K. LTD
Saxham Business Park
Bury St. Edmunds, Suffolk IP 28 6 QZ
Phone: (01284) 76 31 00
www.claas.co.uk

11/04 (GI)

The future is taking shape





Turning innovative ideas into reality

Before we can think about shaping the future, we need to turn to the visionaries of the present.

A group of experts set a number of goals, looked at them again and then redefined them completely. Achieving something out of the ordinary means having the vision to move away from the conventional and set new standards. The highest levels of performance and unparalleled ease-of-use. Innovative design and sophisticated functionality. To be a cut above the rest. These are the objectives of CLAAS. However, even the best of intentions can only be translated into success if they form a perfect link in the forage harvest process chain, thus leading to greater cost-effectiveness

Welcome to CLAAS - the FORAGE HARVEST COMPANY





Good visibility all round

The spacious, air-suspended cab has two seats and consists almost entirely of glass, affording the driver a clear, all-round view of the mower units and road ahead. The all-round windscreen wipers ensure a clear view in all weathers.



The measure of all things - the driver

Any automotive vehicle is only as good as its driver. After all, it's the driver who gets the best out of his machine under any given harvest conditions. That's why we have made every effort during the development of the COUGAR to make the driver's working environment as comfortable as possible.

The adjustable steering column and driver's seat and the clear layout of the switches, levers and pedals are just a few of the features that make working with the COUGAR a pleasure.



Easy access

The cab can be accessed on both sides via wide steps, enabling the driver to descend as he would a conventional staircase. Going to work doesn't have to be a mountain climb.



It's all under control

CEBIS, the electronic on-board information system, keeps you constantly up-to-date. Key data about the COUGAR can be retrieved at the press of a button. Whether you need information about the vehicle or a particular component, all functions and settings can be pre-programmed. The CEBIS terminal is clearly laid-out and can be operated easily and intuitively. Efficiency guaranteed.

Everything within reach

All of the COUGAR's operational functions have been incorporated into ergonomically designed multifunction levers. In a single action, you can regulate the mower unit height on headlands or the individual height of the mower units when mowing tips. You can control the front unit at the press of a button or regulate the overlap of the outrigger mowing units. The extensive width of the mower is comfortably and accurately



controlled from the driving seat. The multifunction lever is integrated into the right armrest and can be individually adjusted to the driver's size. The hand rest ensures comfort and prevents the driver from becoming tired during operation.



Air-con as standard

The fully automatic A/C MATIC air conditioning unit allows you to keep a cool head in hot conditions. Simply enter the desired temperature and leave the rest to the A/C MATIC. If you wish, you can go one extra by adding sun blinds on all sides.



Stay fresh

A refrigerator compartment for cool drinks helps keep your working environment a pleasant one, even on long days.

Visible success

Maximum productivity made fun & easy - job satisfaction guaranteed.

Keeping your eye on the ball at all times need not be stressful. The optimum layout of the two outer mowing units allows for completely accurate parallel tracking and perfect control despite the extensive width of the mower. A quick glance to the right or left is all it takes to fully weigh up the situation. You will quickly get a feeling for the width and capacity of this powerful mower. Excellent visibility and ease of use make for stress-free operation and mean you won't miss a thing. Only working conditions such as these leave no margin for error - even on long hauls - and ensure maximum harvest output. Why not carry out your own endurance test?



Turning night into day

At peak harvest times, you'll probably find the need to work at night. The powerful H9 spotlights are capable of lighting up every last corner of the area you're working on, allowing you to carry on working even in the dark. The COUGAR can be optionally fitted with Xenon spotlights. Perfect visibility even at night means your harvest will always be a success.

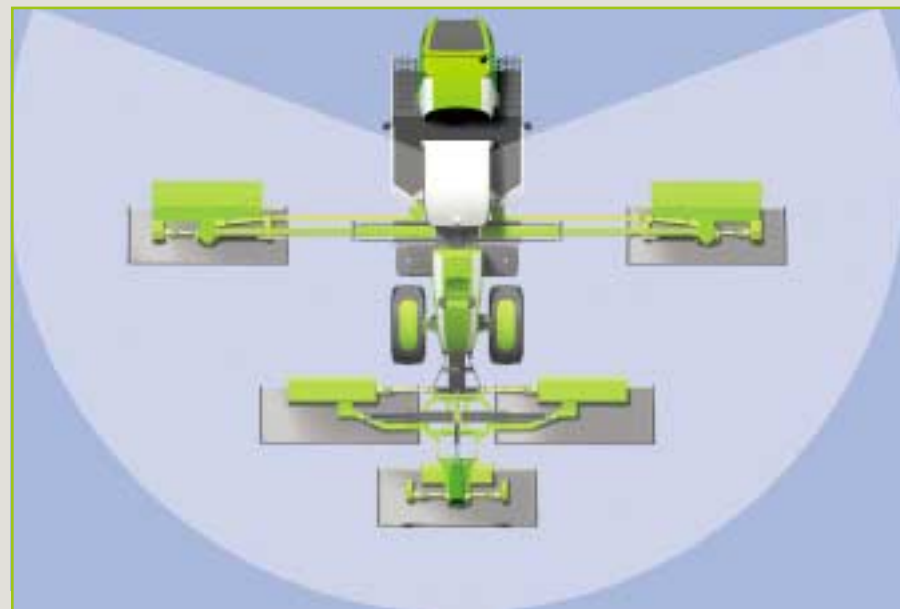

Turning things to your advantage

The revolving cabin gives you excellent visibility in all directions. Rotate the cabin to the desired position at the press of a button. It couldn't be simpler.



For travelling purposes, the mower units are folded behind the driver. The COUGAR's short nose means the driver can assess any given traffic situation through the fully glazed cabin. Perfect and unhindered forward visibility.



At the press of a button, you can rotate the cabin around a central point until it is in the working position. The driver doesn't have to worry about unfolding the mower units or climbing down from the cabin, from where the entire process can be fully controlled. This allows the driver to retain total control of the mower units while they are being unfolded.



In working position, all of the mower units are visible. When your work is done, simply fold the mower units into transport position, rotate the cabin at the press of a button and move on to the next site.

Perfectly managed grass harvest

Rapid headland turns, as few passes over the field as possible and the logical control of all mower units are key to optimum headland management.

You're mowing at high speed and have almost reached the edge of the field. You press the relevant button on the multi-function lever and the mower units begin to raise successively. You turn the COUGAR, whose four-wheel steering system ensures an extremely small turning circle, and continue in the other direction. At the press of another button, you successfully lower the mower units again.

This entire workflow is possible thanks to CEBIS. You can individually adjust the time delay for raising the mower units according to your driving style and harvesting conditions, as well as preset the clearance height and overlap of the mower units.

Ensuring convenience, ease-of-use and maximum mower width - first-class headland management.



Gently does it

Active hydropneumatic mower unit balancing makes it easy to work on ground surfaces of any undulation. The mower units are accurately guided over the ground contour. During mowing, the current balancing pressure is automatically compared with the set value and adjusted accordingly.

The pressure can be set from the cabin using the CEBIS on-board management system, either for all of the mower units or for each one individually, independently of one another. In a matter of seconds, the mower can be adjusted to the relevant field conditions and you can be sure of always achieving the best possible cut.

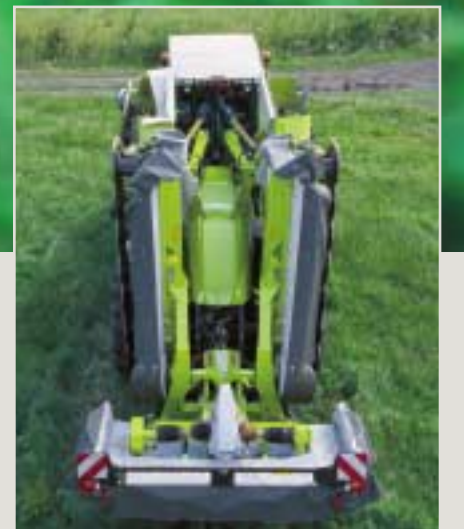

Unlimited flexibility

A sophisticated system for perfect mowing results. Although the COUGAR is able to cope with very large sections, you can effortlessly mow smaller areas, narrow plots or remaining strips. Each mower unit can be individually controlled with the multifunction lever. You can mow with one, two, three or four

mower units - it's up to you. All done with fingertip control and without having to disconnect the drive.

Compact

Stay right where you are. At the press of a button, you can automatically fold up the COUGAR's mower units, including the protective covers. You only need to climb down to open or close gates. Leave the rest to the COUGAR.



Proven mowing technology with a new slant

Cutting-edge mowing technology combined with several years' experience of automotive vehicles. Experience the results for yourself with the COUGAR. Coverage of over 20 ha/hour? No problem whatsoever - our high-powered engineering won't let you down.

At the sharp edge

The mower units feature the tried and tested, extremely sturdy and renowned DISCO cutterbar with oval cutting discs and ground knife cutting of spring steel. The satellite steel ensures trouble-free use even in extreme conditions.

The large depth of the cutterbar, the small size of the service openings in the housing and the extra-strong cover guarantee the durability of CLAAS engineering and ensure that your harvest continues smoothly.



Intelligent operation

The SAFETYLINK safety module offers reliable protection against cutterbar damage in the event of a collision. A defined shear point above the satellite pinion gear prevents any subsequent damage, while a hexagon bolt in the pinion shaft holds the cutting disc in place. In no time at all you can change the pinion gear and bearing or the entire module, allowing you to get straight back to work.



Quick and safe blade changing

The fungiform blade bolt with 7mm overlap is pressed into the disc by a leaf spring. The tungsten carbide coating on the leading edge protects the leaf spring from wear and tear, even under the most difficult of ground conditions.



Intelligent distribution

To ensure that a machine of this size is not susceptible to power loss or failure, intelligent hydraulic control elements have been integrated. There are only two lines to the Control Valve Unit (CVU), a pressure line and a tank line. The CVU handles distribution for 3 other connections, creating a simplistic hydraulic system.



Customise to your requirements

The on-board computer continually delivers information about your vehicle, such as engine temperature or fuel levels. On the other hand, full mower management is integrated into CEBIS. For example, you can set the balancing pressure, the overlap of the outrigger mowing units and the time delay of the mower units at the headlands. Operation is clear and simple, leaving practically no margin for error.



Avoid obstacles automatically

The outrigger mowing units are equipped with a hydraulic collision protection device. If the mower hits an obstruction, it can swing back. The driver need only press the relevant button on the multifunction lever to restart.



Innovative transmission

The latest in powertrain technology means highly reliable power transmission with long service intervals of 250 hours.





Intelligent technologies

The two telescopic outriggers in the centre of the vehicle make the COUGAR unique. They are made of high-tensile, elastic, fine grained structural steel and are dual telescopic, including the driveshafts for the mower units. Although light-weight, they are durable and solid. Energy chains carry all cables and lines cleanly and securely to their connection points. Thanks to telescopic technology, the COUGAR is able to remain within the 3m limit during travel, despite its 14m working width.

Hover mower

Intelligent hydraulic valves allow the mower units to adapt to ground contour irrespective of vehicle height. You continually adjust the balancing pressure, keeping it constant. It can be conveniently controlled from the cabin.



Highly sensitive

An integrated position sensor on the hydraulic cylinders of the top link and outrigger mowing units allows for precision driving in the position defined in CEBIS. Protected from dirt and violent movement, reliability is assured.

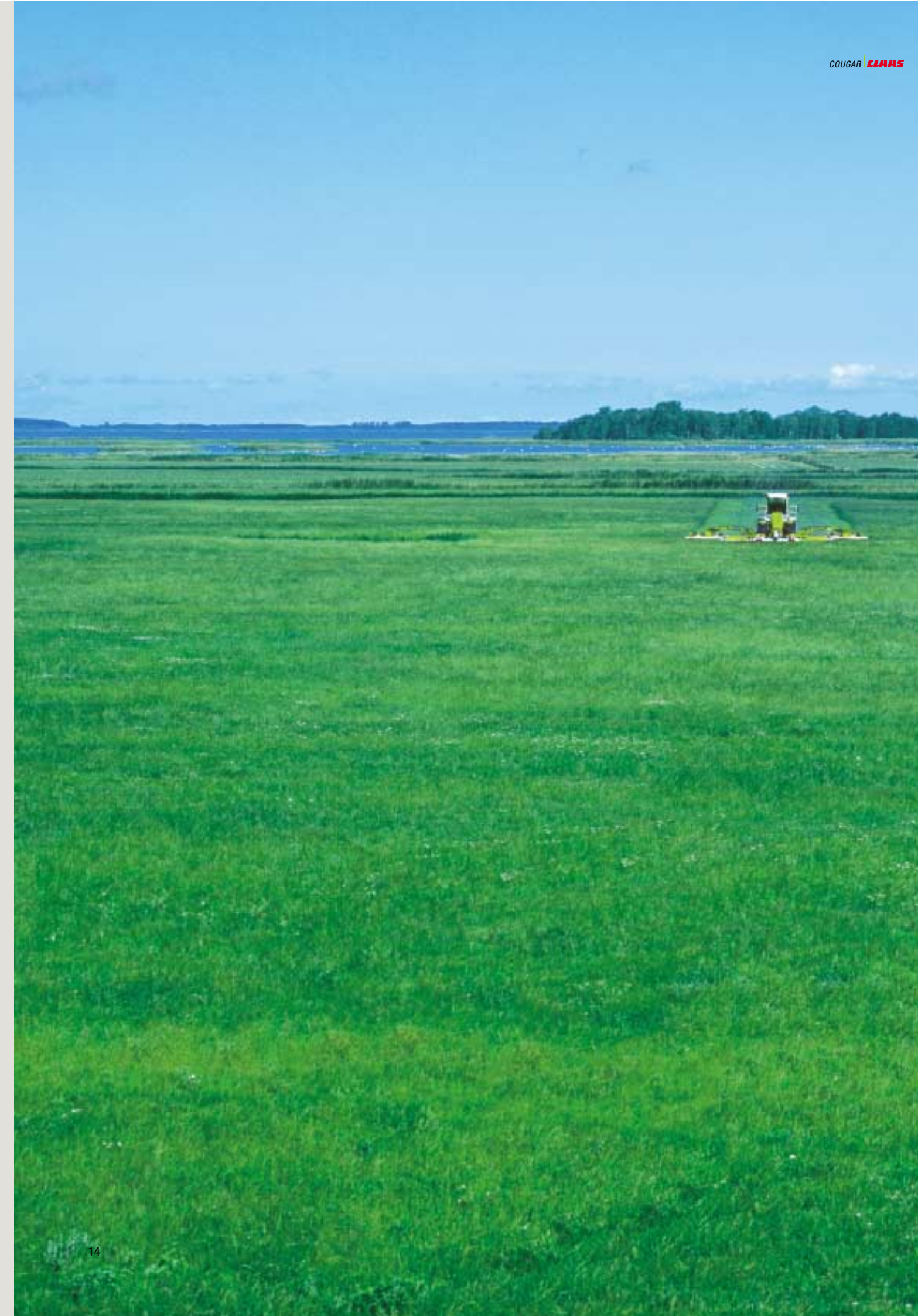

Whatever the weather

A reliable conditioner and crop spreader cowl help you make the most of the brief harvest window. The entire working width is used during crop conditioning, and the crop is stored in a loose, airy swath to dry. Twenty-four hour silage is no problem at all.



Safe and sound

A good harvest necessitates constant mowing. Electronic sensors allow you to recognise and rectify system failures immediately. Each mower unit is therefore fitted with its own speed sensor, which immediately reports any drop in speed. The relevant coupling is automatically shut down. And should another problem crop up, the collision protection device cuts in so that

the mower can swing back, allowing damage to be avoided.

Symmetry is everything

The mowers of the two outrigger mowing units are identically constructed, allowing spare parts to be used on both units. This makes the purchase and storage of replacement parts considerably easier.

Surefooted

Power should only be channelled to where it is actually needed. Mechanical four-wheel drive takes care of that. The COUGAR has an extremely tight turning circle, perfect traction even on inclines and is extremely gentle on the sward.



Four wheels of equal size fitted with 800/65-R32, -900/55-R32 or -1050/50-R32 tyres, combined with permanent four-wheel drive at speeds of less than 21km/h, allow you to be easy on the sward. MULTIPASS ensures that the front and rear wheels turn at exactly the same speed, even when cornering.



Feline agility

The COUGAR's electro-hydraulic four-wheel steering system makes it extremely mobile and manoeuvrable, allowing for direct parallel tracking on headlands in a single manoeuvre.

The COUGAR features crab steering for staying true to its line on slopes. Whatever the lie of the land, the COUGAR is able to adapt perfectly to all conditions.

Wherever and however you travel, the COUGAR is always ready to accommodate you.



Intelligent steering

Thanks to its sophisticated and modern steering technology, the COUGAR is a model of stability and smoothness. At small steering angles, steering is similar to single-axle steering where the axle underneath the cab always controls by the steering gear. As with a trailing axle, the mower axle is controlled electronically and follows the steering angle of the driven axle. Only at steering wheel tur-

ning angles upwards of 4° are both axles turned, increasing mobility considerably. The COUGAR's modern steering technology means that striping during mowing is no longer an issue.

The four-wheel steering system is controlled by sensors on the axles, which transmit the steering lock angle directly to the hydrostatic axle pivot steering control.



Streetwise

You can travel between fields at speeds of up to 40km/h, allowing you to get from place to place quickly. The COUGAR has a transport width of 3m, which means accessibility is never a problem.

Work through the harvest at your pace. Rapid availability and unparalleled flexibility are just what the COUGAR is designed for.

Flexibility and stability



The effective conversion of power into results without wasting energy. Hydraulic where required, mechanical where possible. It's a proven concept.

Two hydraulic motors connected in parallel mechanically transfer power to a two-speed gear, from where it is transferred to the axles via prop shafts.

The latest in powertrain technology allows power to be transferred to the mower units with virtually no dissipation loss. The mowers are also safeguarded by clutches.

The electronic transmission drive gives you two variable gears: for mowing at speeds of 0-21km/h and travelling at between 0-40km/h. Automatic engine control on road journeys allows you to save fuel and keep noise to a minimum.



Elastic

A strong composite V-belt transfers the power directly and reliably to the drive of the outrigger outer mowing units. Through the elasticity of the connection, the drive can be engaged smoothly and gently.



Harnessing horsepower effectively; driving power is fully exploited. You can now achieve output you could have only dreamt of.



Grip

Optimum grip is ensured by two rigid axles coupled to the rubber-mounted pivoting joint in the centre of the frame. An equal load is distributed between all four wheels at all times. Weight distribution remains optimal. Careful avoidance of ground damage, the ability to remain true to your line, tilt resistance even on extreme inclines and equal power distribution to all four wheels ensure that you are always easy on the sward.

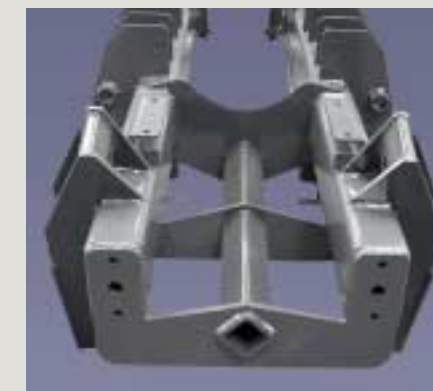

Buffered

The chassis of the COUGAR comprises two independent frames of high-strength, torsionally flexible steel. The cabin sits on the frame where the engine is located, and the mower units have their own frame.



In between, the rubber-mounted pivoting joint compensates for all of the COUGAR's movements. This allows the two frames to twist in different directions while keeping the mower units stable and preventing vibration. This sophisticated design allows the COUGAR to adapt effortlessly to all ground contours, at the same time ensuring optimum smoothness and driving comfort.

A strong heart

Extraordinary off-road mobility, a huge capacity of up to 22ha/hour and speed on the open road are the characteristics that best describe the concept behind the COUGAR.

The powerful in-line six-cylinder engine from DaimlerChrysler, coupled with the variable electronic transmission drive, guarantees high-end performance.

Working speeds of up to 21km/h ensure maximum per-hour output. Road speeds of 40km/h allow you to reduce time spent between fields to a minimum.

Powerful

The powerful drive assembly from DaimlerChrysler, which boasts an engine output of 350kW/480hp, delivers the huge grunt that the COUGAR needs on a daily basis. Electronic fuel-injection ensures both optimum response and low fuel consumption. The time between services is long at 500 hours. The elastic coupling between engine and chassis minimises noise and vibration. Enormous power combined with maximum driving comfort.



Breathe easy

Residual grass that collects in front of and in the radiator is blown out by the COUGAR's reversible fan. You can choose between manual operation at the press of a button, or automatic operation, the timing of which is defined in CEBIS.



The COUGAR - breaking all records

The COUGAR not only allows you to achieve optimum output but also delivers exemplary operability. Even in the most difficult conditions, getting the best from your COUGAR is effortless thanks to its extreme power and impressive ease-of-use.



Keeping cool is half the battle

The COUGAR's stacked radiators allow for optimum cooling in all harvest conditions. The large surface areas of the sieves keep air speed low and thus the accumulation of dirt to a minimum. Driven by the airflow of the fan, a cleaning rotor prevents dirt from accumulating in the radiator fins.



Minimum maintenance, maximum operating time

Because you have to take advantage of good weather during the forage harvest, every second counts. Downtime is not only irritating but also reduces output, efficiency and, ultimately, profit. The COUGAR is based on cutting-edge technology that allows maintenance effort to be kept as low as possible.

High accessibility

Major servicing of the engine can be completed quickly. Every component is easily accessible from all sides.

Stay cool

The radiator is opened with the minimum of fuss. Each sieve is moveable and can be cleaned easily.

Maximum comfort

From time to time you'll need to clean the filter in the cabin roof. This will enable the air conditioning unit to operate at its best, keeping you comfortable whatever the temperature outside.



Minimum downtime

New blades for a perfect cut. No messing with screws. The rainproof blade box is removable, allowing you to change the blades on the spot.

Fewer pitstops

The large fuel tank holds 960 litres of diesel. The benefits of low fuel consumption, high tank capacity and extended and uninterrupted operation are now yours for the taking.

Low maintenance

Easy access gets you off to a good start. The battery compartment is located on the left hand side and is easily accessible for maintenance purposes. A spacious storage compartment on the right hand side can be easily accessed when climbing to the cabin. It provides adequate space for storing tools or spare parts.

No time to lose

The integrated compressed air unit allows you to simply blow dirt away. Cleaning can be carried out straight away and residual grass remains in the field. Furthermore, you can clean the cabin filter and radiator at any time. Pneumatic tools can also be connected, making on-site maintenance much easier.



Highlights

- Spacious, ergonomically designed cabin with excellent all-round visibility.
- Clear view of all 5 mower units.
- Optimum headland management at the press of a button.
- Quick and easy control using CEBIS.
- Powerful drive assembly delivering 350kW/480hp for excellent performance and low fuel consumption.
- Electronic two-speed transmission drive.
- Electro-hydraulic steering.
- Axles and mower units directly driven for optimum conversion of horsepower into mowing performance.
- Innovative folding design reduces 14m working width to a much smaller travel width.



Specifications

		COUGAR 1400
Working width	m (DIN)	14.00
Travel width dep. on tyres used		
	800/65 R32	m
	900/55 R32	m
	1050/50 R32	m
Travel length	m	11.50
Travel height dep. on tyres used	m	3.96
Engine	Type	DaimlerChrysler OM 457 LA
Cylinders		line, 6
Engine output	kW/hp	350/480
Capacity	L	12
Fuel tank	L	960
Transmission drive, 2-range		hydrostatic-mechanical
Four-wheel drive, mechanical		Series
Four-wheel steering system, hydrostatic		Series
Discs	No.	5 x 7
Blades per disc	No.	2
Blade dimensions	mm	115 x 48 x 4
Blade attachment		Quick blade change
Cutting height	mm, approx.	40
Adjustment range	mm, approx.	30-70
	With additional runners	mm, approx. +30
Conditioner speed	rpm	900/770
Weight dep. on equipment	kg, approx.	18.500
Cabin with air conditioning		Series
	Seat air-cushioned	Series
	Passenger seat	Series
CEBIS on-board information system		Series

Subject to changes. Figures and illustrations are approximate and may also refer to optional extras that are not delivered as standard. Please refer to the specifications price list of your local CLAAS dealer. Protective guards may have been removed for photographic purposes in order to illustrate functionality more clearly. All machinery complies with current machine guidelines and regulations.

COUGAR